

DE 93

Los Alamos National Laboratory is operated by the University of California for the United States Department of Energy under contract W-7405-ENG-36.

TITLE: EXPERIMENTAL STUDY OF INSTABILITY GROWTH PATTERNS OF A SHOCK-ACCELERATED THIN FLUID LAYER

AUTHOR(S) JEFFREY W. JACOBS (UNIV. OF ARIZONA)
DAVID G. JENKINS (GRAD. RESEARCH ASSISTANT)
DAVID L. KLEIN (GRAD. RESEARCH ASSISTANT)
ROBERT F. BENJAMIN, M-6

SUBMITTED TO PROCEEDINGS OF THE 4TH INTERNATIONAL WORKSHOP ON THE PHYSICS OF COMPRESSIBLE TURBULENT MIXING (29 MARCH - 1 APRIL 1993 at CAMBRIDGE, ENGLAND)

DISCLAIMER

This report was prepared as an account of work sponsored by an agency of the United States Government. Neither the United States Government nor any agency thereof, nor any of their employees, makes any warranty, express or implied, or assumes any legal liability or responsibility for the accuracy, completeness, or usefulness of any information, apparatus, product, or process disclosed, or represents that its use would not infringe privately owned rights. Reference herein to any specific commercial product, process, or service by trade name, trademark, manufacturer, or otherwise does not necessarily constitute or imply its endorsement, recommendation, or favoring by the United States Government or any agency thereof. The views and opinions of authors expressed herein do not necessarily state or reflect those of the United States Government or any agency thereof.

By acceptance of this article, the publisher recognizes that the U.S. Government retains a nonexclusive, royalty-free license to publish or reproduce the published form of this contribution, or to allow others to do so, for U.S. Government purposes.

The Los Alamos National Laboratory requests that the publisher identify this article as work performed under the auspices of the U.S. Department of Energy.

MASTER

Los Alamos Los Alamos National Laboratory Los Alamos, New Mexico 87545

Experimental study of instability growth patterns of a shock-accelerated, thin fluid layer

J. W. Jacobs

Department of Aerospace and Mechanical Engineering
University of Arizona, Tucson, AZ 85721

D. G. Jenkins, D. L. Klein, and R. F. Benjamin

Los Alamos National Laboratory
Los Alamos, NM 87545

We have discovered a remarkable set of flow patterns induced by shock acceleration of two nearby, perturbed interfaces. Using planar laser-induced fluorescence (PLIF), we observe three distinct patterns in the nonlinear evolution of Richtmyer-Meshkov (RM) instabilities associated with this flow. We observe two patterns dominated by vortex pairs and one pattern showing no vortex pairing (until late time) for initial conditions that are indistinguishable by measurement techniques available for our work. The flow is initiated by spatially periodic perturbations imposed on a "gas curtain" interacting with a planar shock wave. These flow patterns are not predictable nor controllable in our experiments. Our measurements appear to be the first observations of a shock-driven flow exhibiting characteristics of bifurcation. Results were recently published,¹ and more detailed results are forthcoming. We present here a brief description of the experiment, summary of results, and a vortex-based explanation of the phenomena.

Our technique for forming an interface between fluids is an improvement over previous methods using a membrane or gravitational stratification. The vertically-flowing "gas curtain" is a quasi-planar, laminar jet flowing transversely to the direction of shock-wave propagation (shown schematically in Fig. 1). The gas/gas interfaces on both sides of the jet are diffuse with thickness of only ≈ 1 mm. The technique is an extension of work with transverse cylindrical jets used to study vorticity production and evolution.²

We use a shock tube to produce a Mach 1.2 shock wave (in air) to impinge on the gas curtain. Essential parts of the test section are shown in Fig. 1. A schlieren system (not shown in Fig. 1) checked for stabilization of the jet before initiating the shock wave. The diagnostic technique uses PLIF flow visualization to observe the shock accelerated transversely flowing gas jet.² The PLIF diagnostic consists of sheet illumination by a dye laser beam, and imaging by an intensified, gated CCD camera having a frame duration of

5 μs . We acquire only one frame per experiment, and use our judgement to assign it to one of the three patterns. Thus, the three patterns shown in Fig. 2 are representations of time sequences of each of the three patterns. However, each representation is an ensemble of many experiments. Future experiments will attempt to image multiple frames per experiment. The validity of this tracer-based method to image the flow at Mach 1.2 is confirmed by recent results of Budzinski,³ who used Rayleigh scattering to measure the same properties of shock-accelerated cylindrical jet, as did Jacobs with PLIF.² Our attempts to use schlieren imaging to detect the free-stream flow patterns failed because optical distortion by boundary effects obscured the flow patterns in the free-stream region of interest.

The observed flow patterns evolve from a shock-accelerated SF_6 gas jet (i.e., the “gas curtain”) initially having a varicose cross-section, as shown in Fig. 1. The interfaces on both sides of the jet undergo Richtmyer-Meshkov instability when accelerated by a planar shock. Assuming the interfaces behave independently, one expects the first interface encountered by the shock, i.e., the air- \rightarrow SF_6 interface, to experience perturbation growth after shock compression, whereas one expects the second interface, i.e., SF_6 - \rightarrow air, to invert phase before growing. Thus, the varicose cross-section is expected to transform into a sinuous cross-section with growing amplitude after phase inversion, if the interfaces grow independently. This occurs about 40% of the time as shown by the ensemble of PLIF images presented in the middle row of Fig. 2. However, some experiments produce mushroom-shaped profiles, characteristic of vortex pairing, either on the upstream side of the mean interface position, upper row of Fig. 2, or on the downstream side, lower row of Fig. 2. The “upstream mushrooms” occur about 50% of shots and the “downstream mushrooms” about 10%. For initial conditions which are indistinguishable by measurement techniques available for our work, we observe that the intermediate growth stage of this Richtmyer-Meshkov flow evolves unpredictably into one of three distinct sets of patterns during each experiment.

These phenomena can be described qualitatively by the dynamics of the vorticity in these flows, shown schematically in Fig. 3. Vorticity is produced by the misalignment of pressure and density gradients, sometimes referred to as the baroclinic generation of vorticity. Because the dominant pressure gradient is produced by the shock front, and the dominant density gradient is at the boundaries of the gas layer, vorticity produced by the shock interaction will lie on the boundaries of the layer, and will vary periodically along the layer as a row of distributed vortices having alternating sign. We postulate that the diffuse nature of the interfaces enables the vorticity at both interfaces to couple, and form

either a uniform distribution or pairing. The pairing is manifest as upstream and downstream mushrooms. The sinuous pattern would be produced by a more uniform distribution. Subtle asymmetries in the initial conditions may favor one of these three modes in each experiment. Because we do not observe upstream and downstream mushrooms in a single frame during the first millisecond of growth, we suggest that the pairing mechanism is a collective phenomenon. Our model is not yet precise enough to quantitatively estimate how much initial asymmetry is needed to induce pairing.

We have attempted to quantify these images by extracting the growth rate of the peak-to-peak perturbation. We measure the width, W , of the envelope enclosing the perturbed SF_6 layer; we do not measure the peak-to-peak amplitude of each wavelength. The W vs time data have considerable scatter. We have fit the experimental data to the function, $W = W_0 (1 + At)^n$, where we estimate the initial width, W_0 , and treat A and n as fitting parameters. We find that $n \approx 1/2$ for all three patterns. This result is preliminary, and must be compared with future multi-frame data.

Attempts to simulate these flows observed experimentally have been made at Los Alamos⁴ and Lawrence Livermore National Laboratories.⁵ These calculations find that initial upstream-downstream asymmetries of the perturbation amplitudes can produce sinuous-shaped and mushroom-shaped flow profiles. Also the Los Alamos calculations show that initially symmetric perturbations of sufficiently large amplitude can evolve into the mushroom shape mode. These simulation results are preliminary and we expect that future calculations will elucidate the possible mechanisms causing this bifurcating flow.

In summary, we present flow visualizations showing a bifurcating flow associated with the Richtmyer-Meshkov instability of contiguous interfaces. The shock-accelerated gas curtain evolves into one of three distinct flow patterns in each experiment. The flows can be explained qualitatively in terms of shock-induced vorticity production and transport. Models, simulations, and multi frame experiments are needed to understand these flows.

The shock tube experiments were performed at the Los Alamos National Laboratory, supported by US Department of Energy Contract W7405-ENG-36, following nozzle development at the University of Arizona. We are grateful to R. Reinovsky and H. Rogers for encouragement, to R. Haight for use of the intensified camera, and to C. Findley and D. Bannerman for technical assistance.

Figure captions

1. Experimental setup. The shock wave moves left to right at Mach 1.2. The interaction cross-section, denoted I X-S, is the portion of the shock-accelerated gas jet that is illuminated by the laser sheet. The vertical jet is formed by the SF₆ nozzle, and SF₆ is removed in the exhaust plenum below the test section. The camera is an intensified CCD camera that captures one image per event.
2. Experimental data. Each row is a representation of time sequence of a flow pattern. The upper row shows "upstream mushrooms," the middle row shows the sinuous pattern, and the lower row shows "downstream mushrooms." Each row is actually an ensemble of images from different events. Adjacent images are at $\approx 100 \mu\text{s}$ intervals.
3. Vorticity by the pressure gradient of the shock wave and the density gradient of the interface (a) was expected to produce a sinuous profile (b), based on the assumption of uniform vorticity distribution (c). The observations suggest that the deposited vorticity causes pairing (d) and (e), or remains more uniform (f).

References

- (a) Present address of D. G. Jenkins is University of Chicago.
- (b) Present address of D. L. Klein is University of California, Berkeley.
1. J. W. Jacobs, D. L. Klein, D. G. Jenkins and R. E. Benjamin, "Flow patterns in a shock-accelerated thin fluid layer," *Phys. Rev. Lett.* **70**, 583-6 (1993).
2. J. W. Jacobs, "Shock-induced mixing of a light-gas cylinder," *Journal of Fluid Mechanics* **234**, 629-49 (Jan. 1992).
3. J. M. Budzinski, "Planar Rayleigh scattering measurements of shock-enhanced mixing," PhD. thesis, California Institute of Technology, 1992. A preliminary account is given in John M. Budzinski, Edward E. Zukoski, and Frank E. Marble, "Rayleigh scattering measurements of shock-enhanced mixing," AIAA 92-3546, p. 1-15, proceedings of the 28th Joint Propulsion Conference and Exhibit (July 6-8, 1992, Nashville TN).
4. R. Gore, Los Alamos National Laboratory, private communication.
5. W. P. Crowley, Lawrence Livermore National Laboratory, private communication.

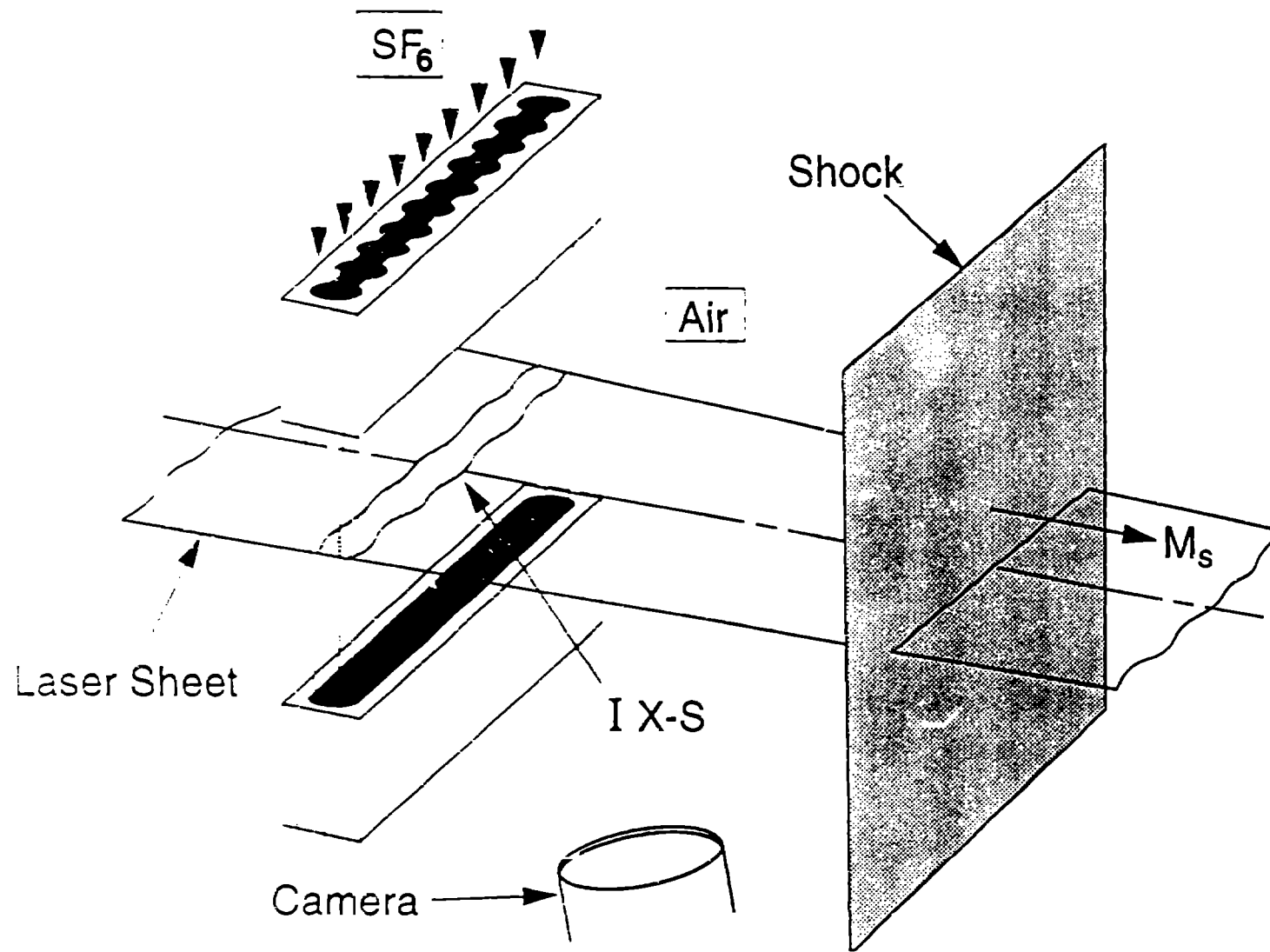

Figure 1

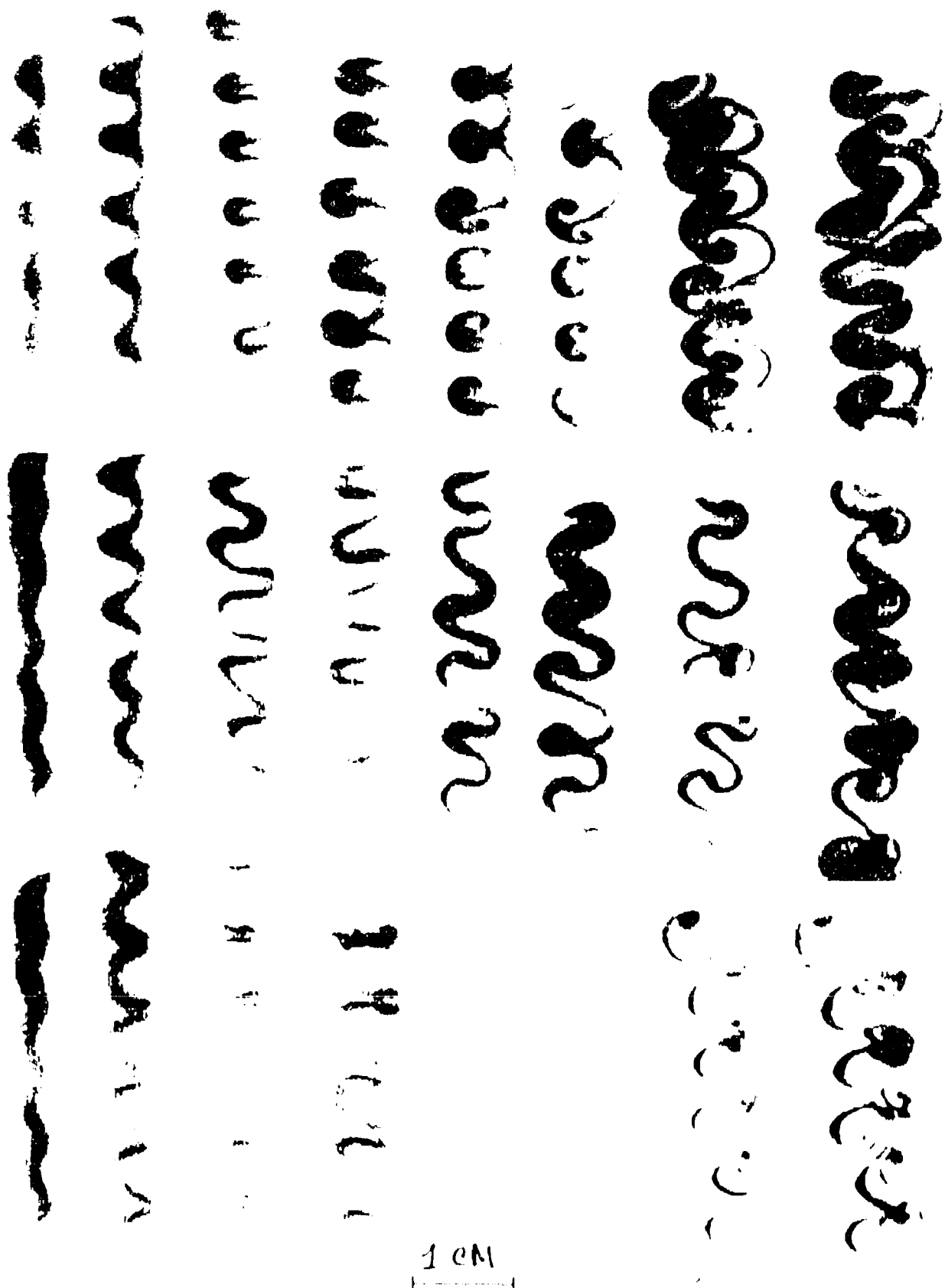

Fig. 2

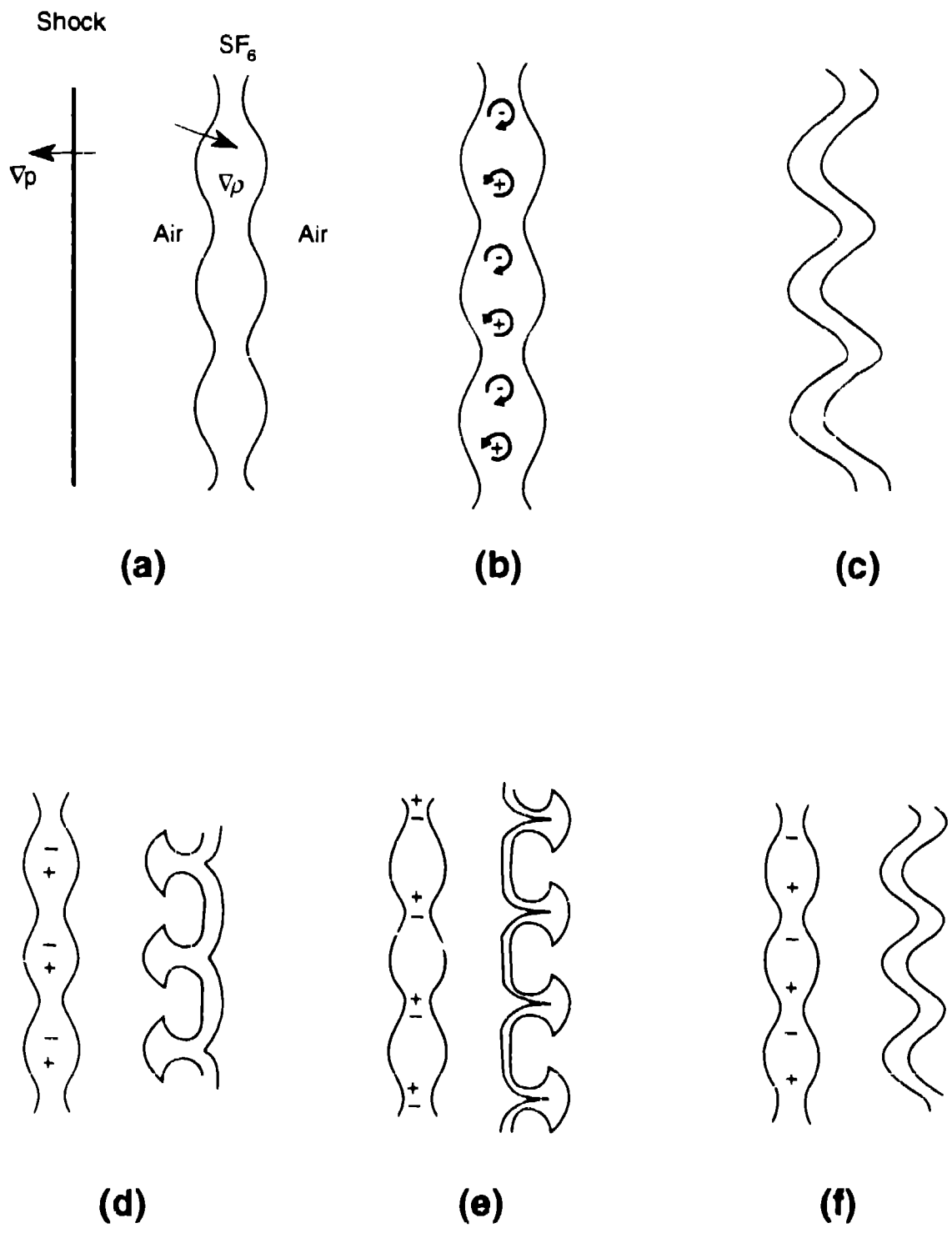

Figure 3